

Industrial Damper • 10" Deep • Airfoil Blades • Channel Frame • Hot Rolled Steel • 800°F Max Temperature

For use up to 15 in. w.g. static pressure

STANDARD CONSTRUCTION

- FRAME:** 2" x 10" x 2", 10 GA. hot rolled steel formed channel frame.
- BLADE:** 10 GA. hot rolled steel, airfoil design, to a maximum 60" length.
- SHAFT:** 1" dia. plated cold-finished steel, corrosion resistant, for up to 48" in length. 1" dia. for up to 60" length.
- BEARINGS:** Stainless steel flanged sleeve, bolted to the frame.
- LINKAGE:** ½" dia. inter-connecting rod with trunnion pivot fasteners, located in jamb.
- OPERATOR:** Manual hand quadrant or lever arm for motor actuator. Specify type when ordering.
- FINISH:** Mill.
- TEMP. LIMIT:** 800°F
Consult the factory for temperature limits over 800°F.

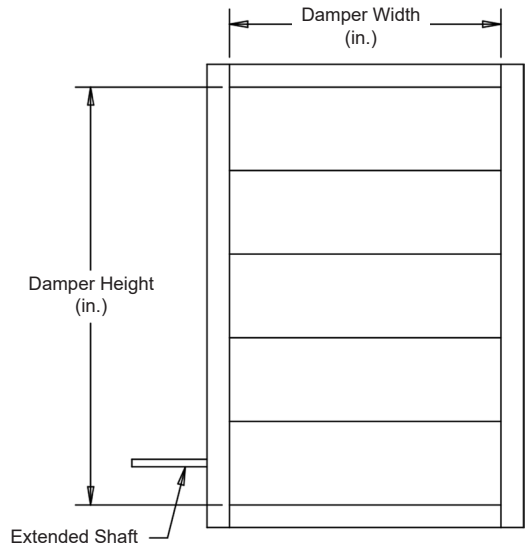

OPTIONS

- Stuffing boxes and replaceable packing
- Jamb Seals - Stainless steel
- Blade Edge Seals - Stainless steel
- Flanges other than the standard 2" wide
- Finishes - Acrylic, baked enamel, etc.
- Perimeter holes: one flange or two flanges
- Other types of bearings
- Materials - Corten available

NOTES

1. ¼" nominal deduction will be made to the opening size given.
2. Construction may be with other materials when required to meet special conditions, such as: temperature, pressure, velocity, system environment, or other specifications.
3. This damper is not available in stainless steel.
4. Approximate shipping weight is 18 lbs./sq.ft.

DAMPER SIZES

Min. Size	Max. Size
6"W x 6"H (Single Blade)	60"W x 96"H
6"W x 12"H (Opposed)	

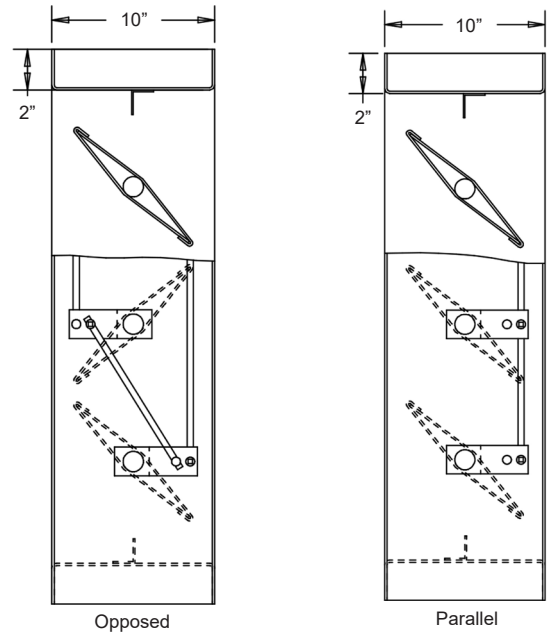

Not to scale.

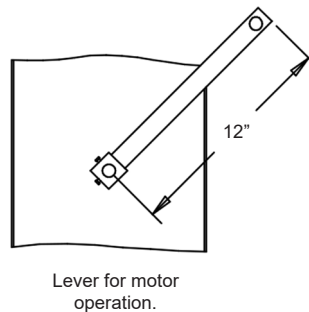
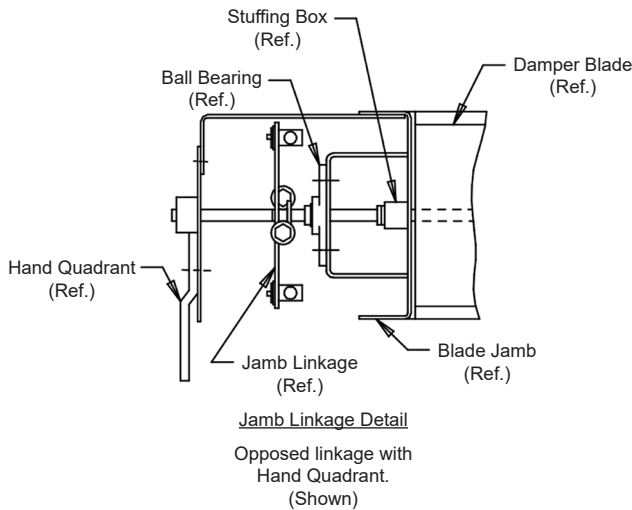

For handwritten orders, use the schedule block on page 2.

In the interest of product development, Louvers & Dampers reserves the right to make changes without notice.

www.louvers-dampers.com

450 Riverside Drive • Wyalusing PA, 18853 • Phone 570-746-1888 • Fax 570-746-9286

